

PLAN  
SCALE: NONE (1)

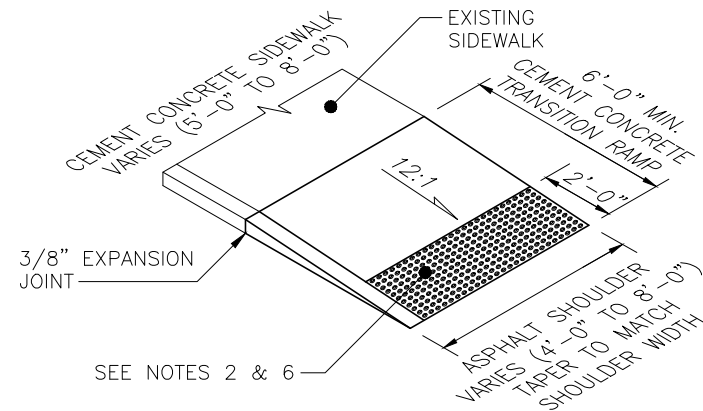

TRANSITION CURB RAMP

DETAIL (2)  
SCALE: NONE

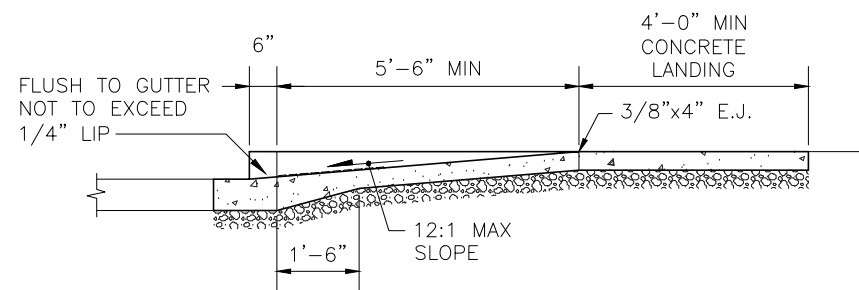

PERPENDICULAR CURB RAMP

SECTION (A)  
SCALE: NONE

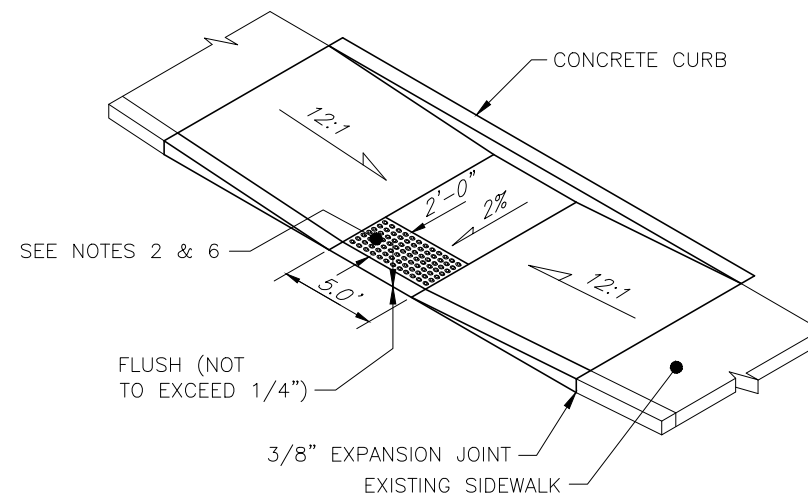

PARALLEL CURB RAMP

DETAIL (3)  
SCALE: NONE

NOTES:

- RAMP AND APPROACHES SHALL BE CLEAR OF OBSTACLES INCLUDING HYDRANTS, POLES, AND INLETS.
- RAMP SHALL HAVE DETECTABLE WARNING SURFACE PER WSDOT STANDARD PLAN F-45.10-01.
- RAMP C SHALL BE PERPENDICULAR TO OR RADIAL TO CURB RETURNS UNLESS OTHERWISE APPROVED BY THE PROJECT REPRESENTATIVE.
- WHERE REQUIRED BY THE JURISDICTIONAL AGENCY STANDARDS, PLACE A 4" WIDE VISUAL WARNING STRIP BETWEEN JOINTS OR SCORES.
- REMOVAL OF EXISTING CURB RAMPS OR SIDEWALK FOR CONSTRUCTION OF NEW CURB RAMPS SHALL BE TO THE NEAREST JOINT. SAWCUT AT EXPANSION JOINT AS REQUIRED. REMOVE SIDEWALK AND CURB AND GUTTER AS REQUIRED TO OBTAIN ADEQUATE SPACING FOR NEW CURB RAMP TRANSITION AND WARNING STRIP(WHERE REQUIRED).
- CURB RAMP LOCATION AND CONSTRUCTION ON ARTERIAL AND RESIDENTIAL STREETS SHALL BE IN ACCORDANCE WITH THE STANDARDS OF THE JURISDICTIONAL AGENCY.

I:\DOT\kingcounty\dot\transit\DC\CAD\_Folders\Projects\passenger\_facilities\standard\_details\2021-2022\standard\_details\D110.dwg | Layout: D110  
 PLOTTED: May 19, 2022 9:08:15pm By: dbernett  
 XREFS: KCMTD-BORDER.dwg  
 IMAGES:

KCMT 2021-2022 STANDARD DETAILS					
No.	REVISION	BY	APPD	DATE	



DESIGNED: K. CHANG YUEN	APPROVED: P. ENG
DRAWN: L. ANDERSON	PROJECT NO.:
CHECKED: K. CHANG YUEN	CONTRACT NO.:
CHECKED: C. ASQUITH	



METRO TRANSIT CAPITAL DIVISION TRANSIT PASSENGER FACILITIES - IMPROVEMENTS	
CURB RAMP CONSTRUCTION DETAILS	

DATE: 05/2022
DRAWING NO: D110
SHEET NO. OF 18 20